



Hisense

Wine Storage Appliance Use & Care Guide

Model:

RW17W4NSWGF

English

WINE COOLER BOTTLE CAPACITY



This chart is provided as a general guide to bottle size. Everyone's collection is different and there are many different bottle size and shapes on the market. The bottle capacity listed for wine storage appliance is for standard Bordeaux 750ml bottles (including champagne and sparkling wine bottles) will decrease the number of bottles you are able to store in your wine storage appliance.

Contents

Brief Introduction	3
Important Safety Instructions	3
Installing Your New Appliance	7
Description Of The Appliance	8
Display Controls	9
Using Your Appliance	11
Cleaning And Care	14
Troubleshooting	15
Disposal Of The Appliance	16

Brief Introduction

Thank you for choosing Hisense. We hope you find your new appliance a pleasure to use. Before you use the appliance, we recommend that you read through these instructions carefully, which provide details about its usage and functions.

Please ensure that all people using this appliance are familiar with its operations and safety features. It is important that you install the appliance correctly and pay attention to the safety instructions carefully.

We recommend that you keep this user's manual with the appliance for future reference and for any future users.

This appliance is intended to be used exclusively for the storage of wine and similar applications such as:

- Kitchen- areas in shops, offices and other working environments;
- Suites in hotels, motels and other residential types of environment;
- Bed and breakfast environments.
- Catering and similar non-retail applications. If you feel that the appliance is not operating correctly, please check the Troubleshooting page for assistance. If still in doubt contact the Hisense customer service help line for assistance or to arrange a call out by an authorized service technician.

Important Safety Instructions



General safety and daily use

The appliance is intended to be used exclusively for the storage of wine as explained in this instruction booklet.



DANGER

The DANGER alert means an imminently hazardous situation. Serious injury or death may occur if not avoided.



WARNING

The WARNING alert means a potentially hazardous situation. Serious injury or death may occur if not avoided.



CAUTION

The CAUTION alert means a potentially hazardous situation. Moderate or minor injury may occur if not avoided.

WARNING

- This appliance is not intended for use by persons (including children) with reduced physical, sensory or mental capabilities, or lack of experience and knowledge, unless they have been given supervision or instruction concerning use of the appliance by a person responsible for their safety. Children should be supervised to ensure that they do not play with the appliance.
- It is dangerous to alter the specifications or modify this product in any way.
- Before any cleaning or maintenance work is carried out, be sure to switch off and unplug the appliance.
- This appliance is heavy. Care should be taken when moving it.
- Take utmost care when handling your appliance so as not to cause any damage to the cooling unit with consequent possible fluid leakages.
- The appliance must not be located close to radiators or gas cookers.
- Avoid prolonged exposure of the appliance to direct sunlight.
- There must be adequate ventilation around the appliance and any damage to the refrigerant circuit must be avoided.
- Do not use other electrical appliances inside of the appliance.
- Do not store explosive substances such as aerosol cans with a flammable propellant in this appliance.
- Keep burning candles, lamps and other items with flames away from the appliance so that they do not set the appliance on fire.
- Do not use extension cords or ungrounded (two prong) adapters;
- If the cord is damaged, it must be replaced by the manufacturer, its service agent or similar qualified person in order to avoid hazard.
- Do not store explosive substances such as aerosol cans with a flammable propellant in this appliance.

WARNING

Keep all ventilation openings clear of obstruction in the appliance enclosure and in the cabinet enclosure.

WARNING

Do not use mechanical devices or other means to accelerate the defrosting process, other than those recommended by the manufacturer.

WARNING

Do not damage the refrigerant circuit.

WARNING

Do not use electrical appliances inside the appliance, unless they are of the type recommended by the manufacturer.

WARNING

Risk of child entrapment. Before you throw away your old refrigerator or freezer:

- Take off the doors.
- Leave the shelves in place so that children may not easily climb inside.

Service/ Repair

•Any electrical work required to install this appliance should be carried out by a qualified electrician or competent person.

This product should be serviced by an authorized Service Center, and only genuine spare parts should be used.

•Under no circumstances should you attempt to repair the appliance yourself. Repairs carried out by inexperienced persons may cause injury or more serious malfunctioning. Refer to your local Service Center, and always insist on genuine Hisense spare parts.

•This appliance contains hydrocarbons in its cooling unit; maintenance and recharging must therefore only be carried out by authorized technicians.

Service Note

This appliance employs Hydrocarbon Refrigerant type R600a. It is hazardous for anyone other than an Authorized Service Person to service this appliance.

Use

- The wine cabinet is designed to be used specifically for the storage of potable wine only.
- Best performance is obtained with ambient temperature as follows:

Ambient Temperature Range

+16 °C to + 43 °C

The class of your appliance is shown on its rating plate.

Note: If the ambient temperature is higher or lower than the above listed, the energy consumption will be affected accordingly.

- Do not store flammable gas and liquid in the appliance, because they may explode.
- Do not place wine directly against the rear wall of compartment.
- The appliance manufacturer's storage recommendations should be strictly adhered to. Refer to Using your appliance.
- The inner lining of the appliance has channels through which the refrigerant passes. Should the channels be punctured the unit could become damaged beyond repair.

DO NOT USE SHARP INSTRUMENTS to scrape off frost or ice. Frost may be removed by using a scraper period. Under no circumstances should solid ice be forced off the liner. Solid ice should be allowed to thaw by defrosting the appliance.

Installation

Important: For electrical connection carefully follow the instructions given in specific paragraphs.

•Unpack the appliance and check if there is any damage to it. Do not connect the appliance if it is damaged. Report possible damage immediately to the place of purchase. In this case retain all packing materials.

•During normal operation, the compressor and/or condenser at the back of the appliance heat up considerably. For safety reasons, minimum ventilation must be as shown in the instructions.

Attention:

Keep ventilation openings clear of obstruction.

•Care must be taken to ensure that the appliance does not stand on the electrical supply cable.

Important: if the power cord is damaged, it must be replaced by a special cord or assembly available from the manufacture or its service agent.

•Do not use extension cords or ungrounded (two prong) adapters.

•If the appliance is transported horizontally, it is possible that the oil contained in the compressor flows in the refrigerant circuit. It is advisable to wait at least two hours before connecting the appliance to allow the oil to flow back in the compressor.

•There are working parts in this product which heat up. Always ensure that there is adequate ventilation as a failure to do this will result in component failure and possible loss. See installation instructions.

•Parts which heat up should not be exposed.

Wherever possible the back of the product should be near the wall.

Electrical Connection

1. The appliance requires a single phase 230V/50Hz power supply. It has a power cord that has a 3-prong grounding plug that minimizes the possibility of electrical shock. This appliance must be grounded. Do not remove the grounding prong or modify the power plug.

2. Do not modify the power plug. The power plug must be accessible when the appliance is installed.

3. The appliance should not be turned off with a switch or other device.

4. Make sure that the plug is not squashed or damaged. Otherwise, it may cause short circuit, electric shock or overheat and even cause a fire.

5. Do not insert the power plug if the socket is loose, there is a risk of electric shock or fire.

6. Switch off the appliance and disconnect it from the main power before you clean or move it.
7. Never unplug the appliance by pulling on the electrical cord. Always grip the plug firmly and pull straight out from the socket to prevent damaging the power cord.
8. Do not operate the appliance without the cover over the interior lighting.
9. Any electrical component must be replaced or repaired by a qualified electrician or Hisense authorized service technician. Only genuine replacement parts should be used.
10. To avoid eye injury, do not look direct into the LED light located in the refrigerator compartment. If it is not functioning correctly, consult a qualified, registered electrician or replace it in accordance with the "cleaning and care" chapter.

Environment Protection

This appliance does not contain gasses which could damage the ozone layer, in either its refrigerant circuit or insulation materials. The appliance should not be discarded together with your local city refuse and rubbish. The insulation foam contains flammable gasses. The appliance should be disposed of according to the applicable regulations of your local government. Avoid damaging the cooling unit, especially at the rear near the heat exchanger. The materials used on this appliance marked by the symbol ♻️ are recyclable.

Use

Cleaning the interior

Before using the appliance for the first time, wash the interior and all internal accessories with luke-warm water and some neutral soap so as to remove the typical smell of a brand-new product, and then dry naturally and thoroughly.

 **WARNING**

Do not use detergents or abrasive powders, as these will damage the finish.

Refrigerant

The refrigerant isobutene (R600a) is contained within the refrigerant circuit of the appliance. During transportation and installation of the appliance, ensure that none of the components of the refrigerant circuit becomes damaged.

⚠ Do not use detergents or abrasive powders, as these will damage the finish.

 **WARNING**



Risk of fire/ flammable materials

The symbol is a warning and indicates the refrigerant and insulation blowing gas are flammable.

Installing your new appliance

Before using the appliance for the first time, you should be informed of the following tips.

VENTILATION OF APPLIANCE

In order to improve efficiency of the cooling system and save energy, it is necessary to maintain good ventilation around the appliance for the dissipation of heat.

For this reason, sufficient clear space should be available around the product.

Suggest: It is advisable for there to be at least 1/2 inch of space from the back to the wall, at least 1/2 inch from its top, and at least 1/4 inch from its side to the wall. As shown in the following diagrams.

Note:

- Avoid locating the appliance in damp areas. Too much moisture in the air will cause frost to form quickly on the evaporator.
- Keep the appliance out of direct sunlight, rain or frost. Position the product away from heat sources such as stoves, fires or heaters.

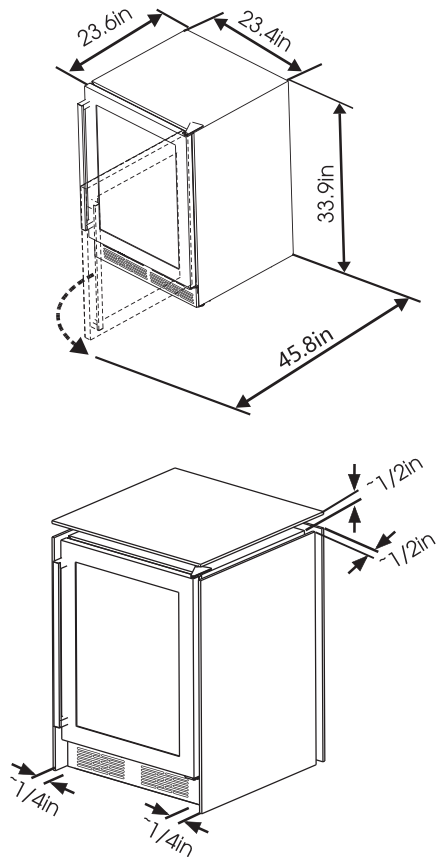

- Position your appliance in a dry place to avoid high moisture.

- This product is used as an built-in appliance, The product needs to be installed in the cabinet or a similar counter, Use the mechani to fix the product to prevent falling.

Leveling Of Appliance

The appliance should be level in order to eliminate vibration. We recommend that you level the appliance by the following steps.

1. Put the refrigerator into the right place.
2. Turn the adjustable feet (with your fingers or a suitable screw driver) until they touch the floor.
3. Tilt back the top backwards for about 10-15mm or 1° by turn the adjustable feet. This will allow the doors f-close providing a consistent closed seal.

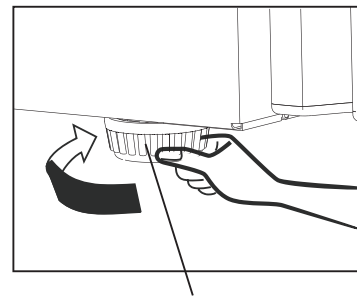

Cabinetleg

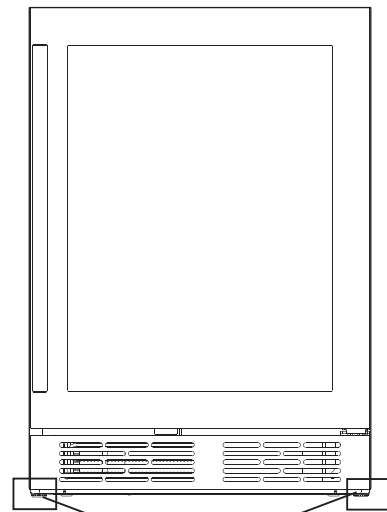

Cabinetleg

Electrical Connection

Caution! Any electrical work required to install this appliance should be carried out by a qualified person or authorized service technician.

WARNING

This appliance must be grounded. The manufacturer declines any liability should these safety measures not be observed.

Description of the appliance

Description of the appliance Equipped with metal shelves

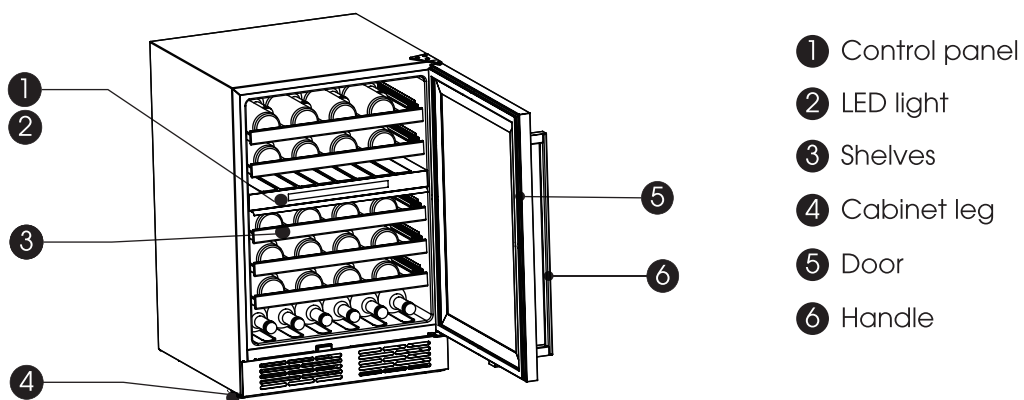

Note:

- The appliance can keep 46 bottles of wine at the same time, please place the wine bottles as shown above.
- Bottle capacities, mentioned in this manual are based on standard BORDEAUX 750ml bottles and standard shelving.

Display Controls



Standby key **A**

Light On/ Off key **B**

UPPER:Temperature control key -Up **C**

UPPER:Temperature control key -Down **D**

Temperature Indicator **E**

I Cancel alarm key

H °F and °C Change key

G LOWER: Temperature control key -Down

F LOWER:Temperature control key -Up

Display

The control panel, shown above, is at the middle of the Refrigerator Chamber.

- Each time the power turns on, the display panel will light everything for 3seconds, beep for 1 second, and then enter the normal display status.
- Icons are always lit (until the screen activates).
- The display will activate the screen saver if no button and no action is taken to open or close the door for 60 seconds with the display on.
- Any button press or open door action will exit the screen saver.
- Press the key in the screen saver state. Activate the screen saver only. Do not change the settings.
- Each valid button press emits a short sound.
- The corresponding temperature setting is reflected in the display, and the setting takes effect and is stored after 10 seconds of operation without pressing the key.

Standby Mode

When you do not plan to use this appliance for a period of time, you can save energy by entering the standby state.

- To enter standby mode, press and hold the standby key for more than 3 seconds. The buzzer will beep and the display board will show "OF".
- To exit standby mode, press and hold the standby key for more than 3 seconds. The buzzer rings will beep.

NOTE: In standby mode, cooling will stop. If you do not use the appliance for a long time, take out the wine, and unplug the unit.

"Light On/Off key"

You can turn the interior light on or off by pressing this button. After closing the door for 10 seconds, the light will turn off automatically, so wine is not exposed to light for too long.

Temperature Measure Change (°F / °C)

You can change the temperature display setting from Fahrenheit to Celsius degrees by pressing the marked ,and vice versa.

Temperature regulation

You can set the temperature you desire by pressing the buttons "▲" or "▼". When you press the button for the first time, the LED readout will show the previously set temperature. The temperature will increase 1°C or 1°F each time you press the UP button and will decrease 1°C or 1°F each time you press the DOWN button.

NOTE:

- The appliance doesn't work properly if the set temperature is higher than the ambient temperature.
- The temperature range is from 5°C(41°F) to 18°C (64°F).
- The temperature preset at the factory is12°C(54°F).
- When you set a temperature, you set an average temperature for the whole cabinet. There may be a 2°C (3.6°F) to 3°C (5.4°F) variance between the top and bottom shelves of the appliance.

Over Temperature Alarm

In order to avoid a the temperature problem that could affect the quality of the wine, the appliance has an overtemperature alarm function. When an over temperature alarm occurs, cancel the alarm by pressing the Cancel Alarm Key and take out the wine, and contact customer service.

NOTE:

In the over temperature alarm state, press the Cancel Alarm Key to exit the over temperature alarm, the alarm tone stops, and the light "⚠" will change from blinking to constant, once the appliance cools to the required temperature.

WARNING

If the LED light is broken, please DO NOT CHANGE IT YOURSELF! Changing the light yourself may cause injury or serious malfunctioning. It must be replaced by a qualified service technician in order to avoid a hazard. Contact your local Service Center for help. Before changing the LED light, switch off the appliance and unplug it, or pull the fuse or the circuit breaker.

Door Alarm

The door alarm will sound once the fridge door is open over 2 minutes. In case of door alarm, the buzzer will sound 3 times per minute and will stop automatically 8 minutes later. Closing the door will also clear the door alarm.

To save energy, don't keep the door open for a long time when using refrigerator.

Using your appliance



This section tells you how to use most of the useful features. We recommend that you read through them carefully before using the appliance.

Installation The Handle

The tools you will need :

Philips Screwdriver (Not provided)

The parts you will need :

	 
Handle (Provided)	Screw (Provided)
1	2 (and there are another 2 screw for backup)

Before using the device, install the handle as follows:
1. First open the door and take the door gasket out on one side of the nonhinged side.

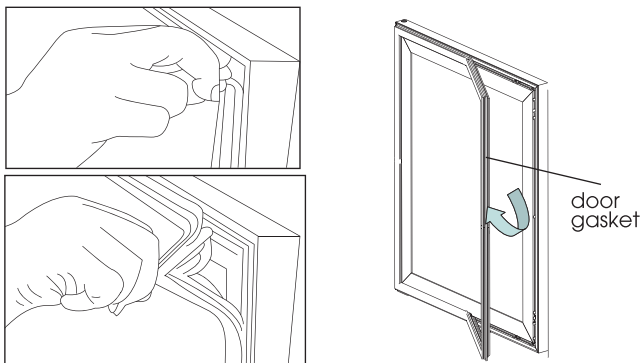

- Find the handle and screws in the accessory pack.
- Attach the screw with a magnetic screwdriver so that it passes through the screw hole in the door body until the bottom. Keep a certain amount of pressure and don't let go.
- One hand holds the handle so that the handle hole is aligned with the screw, and the other hand turns the screwdriver.

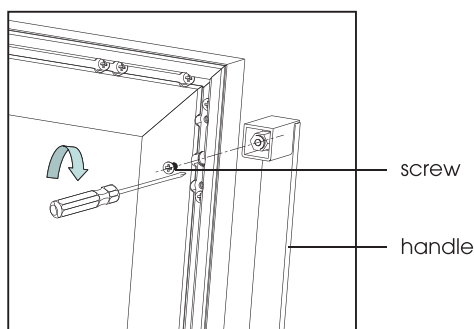

- Install another screw in the same way.

Placement Of Bottles

The appliance is equipped with 6 shelves with 8 slots each. The bottles should be placed on the shelves as shown below.

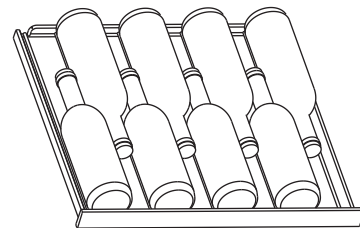

You can also place bottles in the six slots which are located at the bottom of the refrigerator.

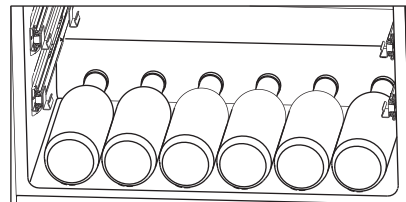

WARNING

- To prevent the bottles from rolling down and being broken, there should not be more than 6 bottles placed at the bottom of the refrigerator room as showed above.
- The maximum loading of each type of shelf is 33lb.

Tips For Keeping The Wine

- Keep the wine in the dark. The door is in anti - UV darkened double glass to protect the wine from the light in case the refrigerator is located in well - lit place.
- Lay the bottles down in such a way that the corks do not dry.
- Avoid switching the appliance light on too often or for too long. Wine keeps better in dark.
- To avoid agitating the wine, handle the bottles with care.
- Follow the recommendations and advice at the time of purchase or given in the technical documentation regarding the quality, duration and optimum storage temperature of the wine.

•The proper storage of wine depends on its age, type of grapes, alcoholic content and level of fructose and tannin contained in it. At the time of purchase, check if the wine is already aged or if it will improve over time.







Reversing The Door



The side at which the door opens can be changed, from the right side (as supplied) to the left side, if required.

WARNING

When reversing the door, the appliance must not be connected to power. Ensure that the plug is removed from the power socket.

The tools you will need (Not provided):

Not provided		
		
8mm socket wrench	Thin-blade Screwdriver	Putty knife
		
Phillips head screwdriver	Adjustable Wrench	8mm wrench

The parts you will need (provided)		
		
Screw hole cover (right)	Top left axle hole part	
1	1	

Note: If required you may lay the refrigerator on its back in order to gain access to the base, you should rest it on soft foam packaging or similar material to avoid damaging the backboard of the refrigerator. To reverse the door, the following steps are generally recommended.

1. Stand the wine cooler upright, close the door, use a putty knife or thin-blade screwdriver to pry off the screw hole cover which is at the top left corner of the cooler, and unscrew the special flange screws which are used for fixing the right upper hinge part by a 8mm socket driver or a spanner (please support the upper door with your hand when doing it).

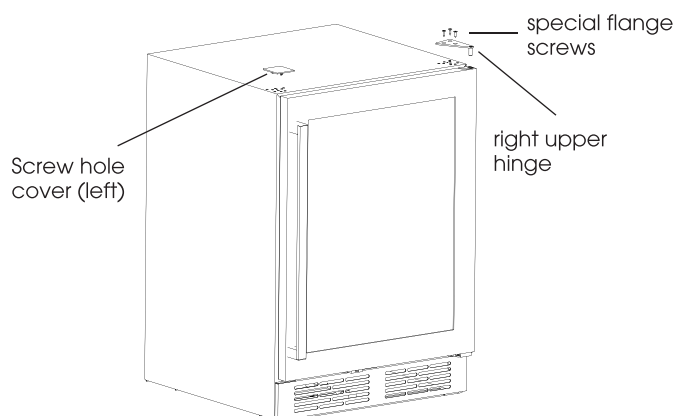

2. Move the door from the hinge by carefully lifting the door straight up.

Note: When removing the door, watch for washer(s) between the hinge and the bottom of the upper door that may stick to the door. Do not lose these washers.

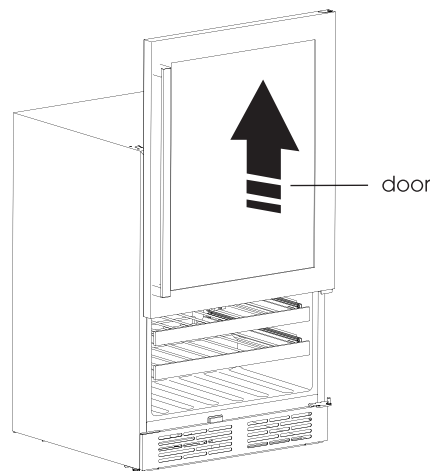

3. Unscrew the grille cover fixing screws then lifting up and pulling backwards, take the grille cover off the cabinet.

Note: Take care of the screws. Record the screw's place of use and quantity.

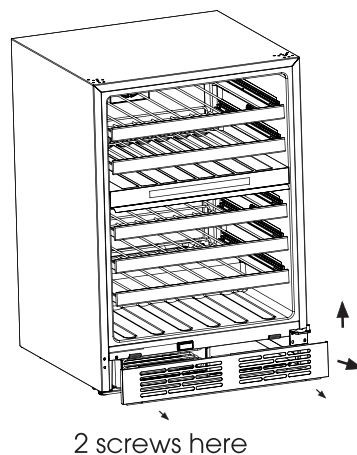

4. Transform the bottom hinge from right to left as following:

4.1 Unscrew the bottom right hinge screws

Note: Keep the hinge for the future use.

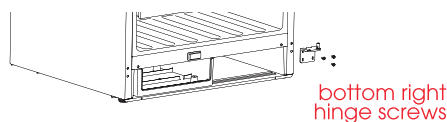

4.2 Transform the bottom right hinge into bottom left hinge, relax the the axis of the hinge and install it on the left hole. Screw up the axis .

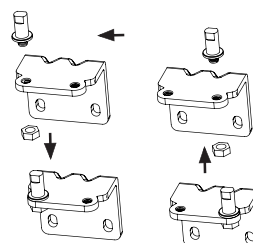

Bottom left hinge

Bottom right hinge

4.3 Install the bottom left hinge on the left side of the cabinet. use the screws fixing.

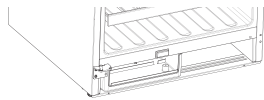

Bottom left hinge
(as transferred)

5. Flip the grille cover from left to right as following:
 1. Pull it out from the left side slot.
 2. Turn it 180 degree.
 3. Put it into the right side slot.

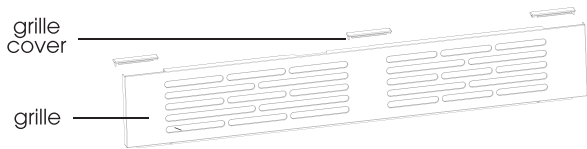

6. Reattach the grille cover to the wine cabinet as shown below.

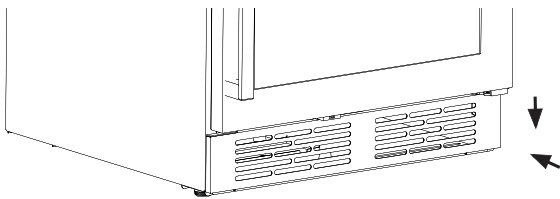

7. Change the axle hole parts of as follows:
 1. Pull out top right axle hole part by knife or thin blade screwdriver.
 2. Turn the door 180 degrees, face to the bottom of the door and remove the reinforcement part and magnet supporter with the screwdriver.
 3. Put the top left axle hole part into the door hole.
 4. Turn the door 180 degrees, Reattach the reinforcement part and magnet supporter using the same screws.

Note: Handle the door carefully. It is fragile.

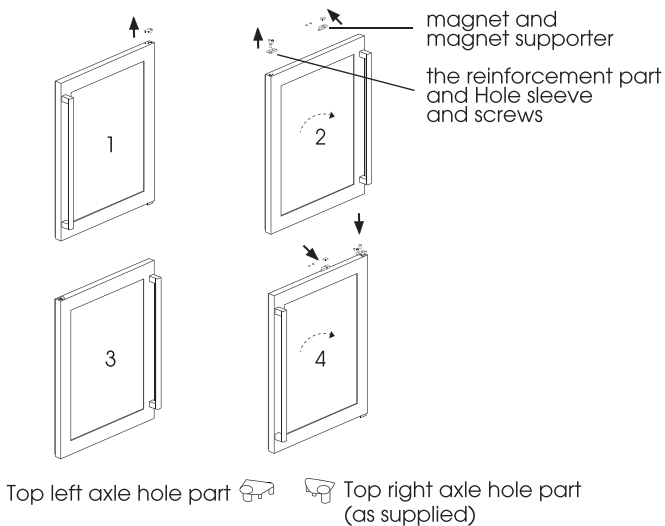

8. Turn the door 180 degrees, put the door on the cabinet using the hinge and screws, on the top left side. Use screw hole cover (right) to hide the holes on the top right side of the wine cabinet.

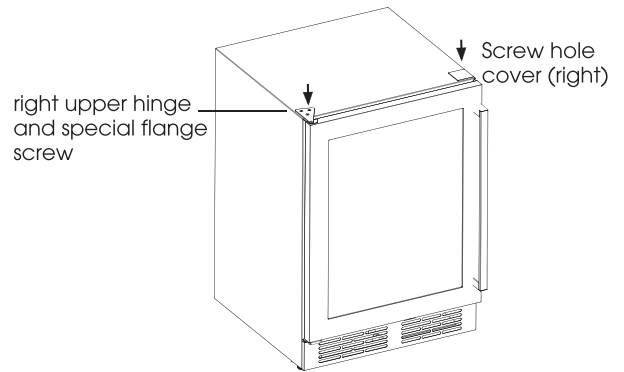

Screw hole cover (right)



Screw hole cover (left)

Wine Serving Temperature Chart

All wines mature at the same temperature, which is a constant temperature set between 12° C(53.6 ° F) to 14°C(57.2 °F). The below chart is an indicative temperature chart to indicate the best temperature for drinking purposes.

Types of wine	Recommended temperature
Champagne NV, Sparkling, Spumante	6°C (42.8 °F)
Dry White Semillon, Sauvign Blanc	8°C (46.4 °F)
Champagne Vintage Dry White Chardonnay Dry White Gewurztraminer Riesling, Pinot grigio Sweet White Sauternes, Barsac Ice Wine, Late Harvest	10°C (50 °F)
Beaujolais	13°C (55.4 °F)
Sweet White Vintage: Sauternes... White Vintage Chardonnay	14°C (57.2 °F)
Red Pinot Noir Red Grenache, Syrah	16°C (60.8 °F)
Red vintage Pinot Noir	18°C (64.4 °F)
Cabernet & Merlot: French, Australian, New Zealand, Chilean, Italian, Spanish, Californian, Argentinean...	20°C (68 °F)

! WARNING

When disposing of your appliance, use an approved disposal site. Remove the plug and ensure that any locks or catches are removed, to prevent young children being trapped inside.

Cleaning and Care

For hygienic reasons the appliance (including exterior and interior accessories) should be cleaned regularly.

WARNING

Before cleaning, the appliance must be powered off and unplugged. Danger of electrical shock!

Exterior Cleaning

To maintain good appearance of your ppliance, you should clean it regularly.

- Spray water onto the cleaning cloth instead of spraying directly on the surface of the appliance. This helps ensure an even distribution of moisture to the surface.
- Clean the door with a mild detergent and then wipe it dry with a soft cloth.

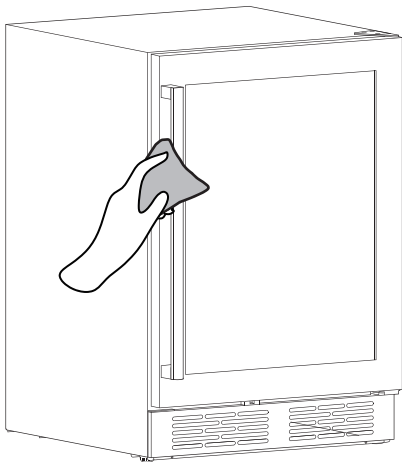

Cleaning The Wine Refrigerator

To clean the wine refrigerator, you should follow these steps:

- Unplug the appliance and remove the bottles.
- Wash the inside with a warm water and baking soda solution. The solution should be about 2 tablespoons of baking soda to 4 cups of water.
- Wash the shelves with a mild detergent solution.
- It may also be necessary to periodically wipe the bottom part of the storage are ,as the wine refrigerator is designed to retain humidity, and condensation may collect there.

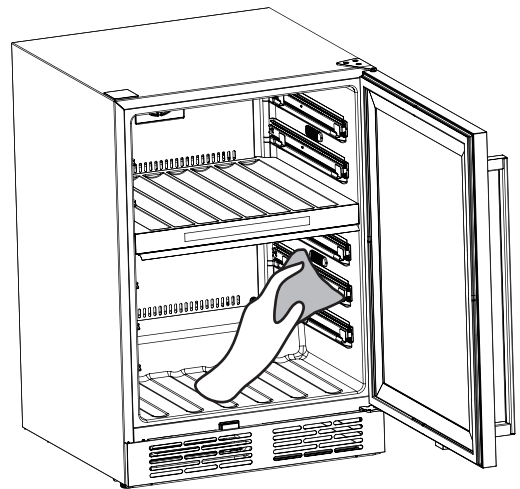

CAUTION

- Don't use sharp objects as they are likely to scratch the surface.
- Don't use Thinner, Car detergent, Clorox, oils, abrasive cleansers or organic solvents such as Benzene for cleaning. They may amage the surface of the appliance and d may cause fire.

Troubleshooting

If you experience a problem with your appliance or are concerned that the appliance is not functioning correctly, you can carry out some easy checks before calling for service, please see below.

WARNING

Don't try to repair the appliance yourself. If the problem persists after you have made the checks mentioned below, contact a qualified electrician, authorized service technician or the store where you purchased the product.

Malfunction	Possible Cause	Remedy
The wine is too warm.	Temperature is not properly adjusted.	Please look in the "Display controls" section.
	Door was open for an extended period.	Open the door only as long as necessary.
	The appliance is near a heat source.	Please refer to the "Installing your new appliance" section.
Heavy build up of frost, possibly also on the door seal.	Door seal is not air tight (possibly after changing over the hinges).	Carefully warm the leaking sections of the door seal with a hair dryer (not hotter than approx. 50 ° C) . At the same time shape the warmed door seal by hand such that it sits correctly.
Unusual noises.	Appliance is not level.	Readjust the feet.
	The appliance is touching the wall or other objects.	Move the appliance slightly.
	A component, e.g. a pipe, on rear of the appliance is touching another part of the appliance or the wall	If necessary, bend the component out of the way carefully.
The compressor does not start immediately after changing the temperature setting.	This is normal, no error has occurred.	The compressor starts after a period of time.
	The setting temperature is higher than the ambient temperature.	Set the temperature lower than the ambient temperature as you want.
Water on the floor.	Water drain hole is blocked.	Please refer to the "Cleaning and care" section.

Disposal of the appliance

It is prohibited to dispose of this appliance as household waste. Please check with your local government for proper disposal procedures.

Packaging Materials

Packaging materials with the recycle symbol are recyclable. Dispose of the packaging into a suitable waste collection container to recycle it.

Before Disposal Of The Appliance

1. Pull out the power cord from the power socket.
2. Cut off the power cord and discard.

WARNING

Refrigerators contain refrigerant and gases in the insulation. Refrigerant and gases must be disposed of professionally as they may cause eye injuries or ignition. Ensure that tubing of the refrigerant circuit is not damaged prior to proper disposal.

	Correct Disposal of this product
	<p>This symbol on the product or in its packing indicates that this product may not be treated as household waste. Instead, it should be taken to the appropriate waste collection point for the recycling of electrical and electronic equipment. By ensuring this product is disposed of correctly, you will help prevent potential negative consequences for the environment and human health, which could otherwise be caused by the inappropriate waste handling of this product. For more detailed information about the recycling of this product, please contact your local council your household waste disposal service, or the shop where you purchased the product.</p>

WARNING: When positioning the appliance, ensure the supply cord is not trapped or damaged.

WARNING: Do not locate multiple portable socket-outlets or portable power supplies at the rear of the appliance.

- This appliance can be used by children aged from 8 years and above and persons with reduced physical, sensory or mental capabilities or lack of experience and knowledge if they have been given supervision or instruction concerning use of the appliance in a safe way and understand the hazards involved.
- Children shall not play with the appliance.
- Cleaning and user maintenance shall not be made by children without supervision. The instructions shall contain details on the use of the appliance to ensure the safe preservation of foodstuffs. Manufacturers should give details on the most appropriate part in the compartment of the appliance where specific types of food shall be stored, considering the distribution of temperature that can be present in the different compartments of the appliance.
- Opening the door for long periods can cause a significant increase of the temperature in the compartments of the appliance.
- Clean regularly surfaces that can come in contact with food and accessible drainage systems.
- If the refrigerating appliance is left empty for long periods, switch off, defrost, clean, dry, and leave the door open to prevent mould developing within the appliance.

Hisense Service Help Line: 0191 387 0804

Hisense
life reimagined

Hisense UK Ltd
Unit2
Meadow Court
Millshaw Lane
LS11 8LZ